

# Bore Gauge BG40



reliable process control

replaces postprocess measuring station

machine-independent measuring system

BLUM

# BG40/BG41

High precision Bore Gauge for the mass production of parts with the same bore diameter

- on-machine measuring
- extremely fast measuring cycle and data transmission
- provides instant process control, calculates tool compensation values, prevents costly production of scrap when tolerance limits are exceeded
- robust construction for durable usage in high production manufacturing environments
- provides closed loop machining by communicating with third party active tools (i.e. adjustable boring bars)
- instant wireless data transmission to machine control or SPC systems
- superior accuracy due to self-contained floating measuring system which is independent from machine axis feedback
- integrated Z axis collision protection
- increased productivity, significant ROI due to elimination of costly post process measuring station

Collision protection generates emergency stop of Z axis

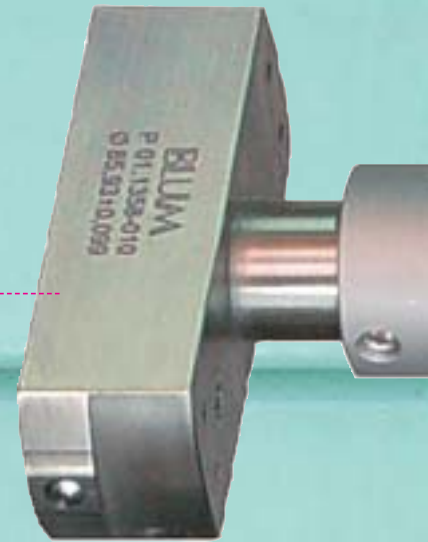

## Custom solution for a variety of applications

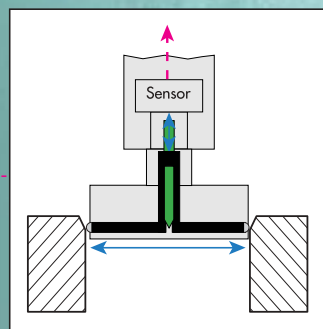

BG40 designed with floating measuring system for diameter measurement only

Ø diameter

### Benefits:

- economical solution
- float principle provides accurate diameter even when machine is not perfectly positioned in bore center
- self-contained, machine independent, measuring principle

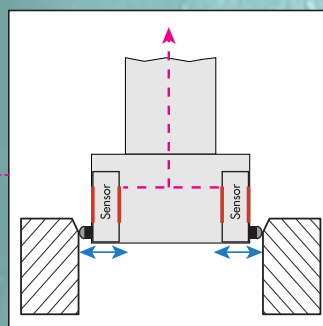

BG41 designed with multiple sensors to measure:

Ø diameter  
⊕ position  
⊘ cylindricity  
○ roundness

### Benefits:

- customized solution to provide complete bore quality characteristics
- self-contained, machine independent, measuring principle

- IC55 maintenance free state-of-the-art IR technology with integrated air nozzle

- hardened glass ring protects electronics
- microprocessor controlled transmission technology
- circularly arranged diodes ensure full 360° IR coverage



- LED display to provide status of function, mode and battery capacity

- standard toolholder for Komet ABS50
- special short tool holder upon request

- easy and fast alignment



- up to 150,000 measurements due to low power consumption
- easy to exchange standard battery

## Applications

---

### Engine block production

Process control for finishing of cylinder bores



### Valve production

Continuous process monitoring and control for honing of highprecision hydraulic valve bores

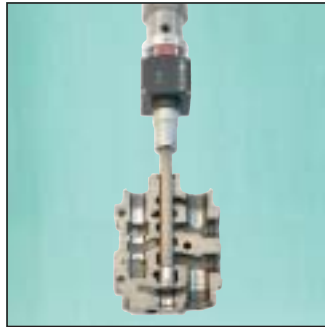

### Cylinder block

Complete process control with active tool:  
machining – measuring – correction  
machining



### Compressor production

Process control for finishing of cylinders for truck-brake compressors

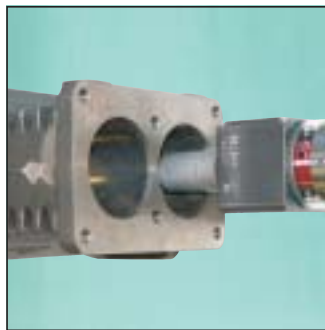

## Special types of multi-function measuring heads

---

### Cylinder block production

Recording the position of a cylinder block after pallet change



Simultaneous measuring of all diameters and concentricity in the crankshaft bearings



# BG40/BG41

## Typical applications:

- Motor production
  - cylinder block bores
  - crankshaft bearings
  - camshaft bearings
  - valves
- Gear production
- Hydraulics
- Mass production of parts with the same bore diameters

# BG42

Customized solution with up to 8 individual measuring elements

# BLUM

# BG40

## Simplified version of a process control flow diagram

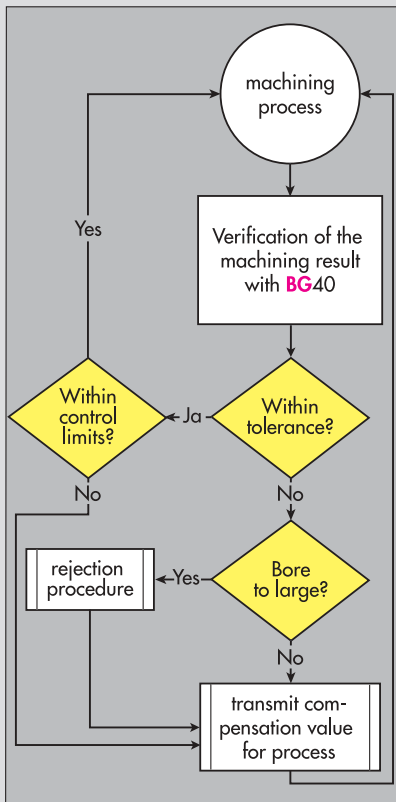

### Benefits: Cost savings due to

- Unmanned operation
- Improved part quality
- Reduction of defective parts

## System Solutions by BLUM

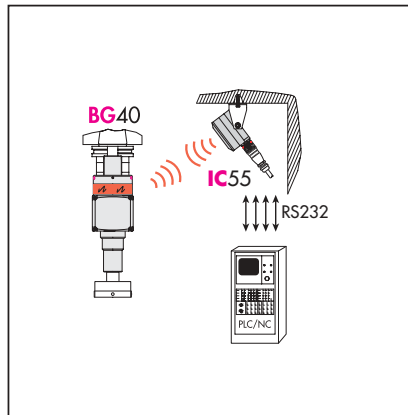

Standard connection via V24 Interface Control and measuring result evaluation through machine control system

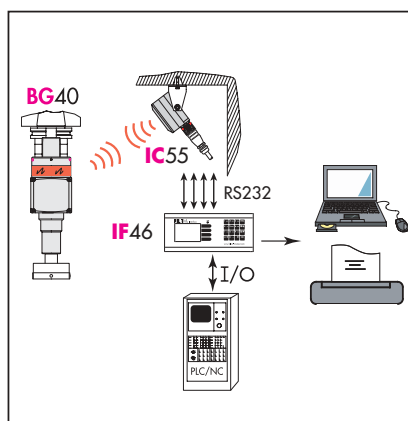

Easy integration with BLUM Logic Interface IF46

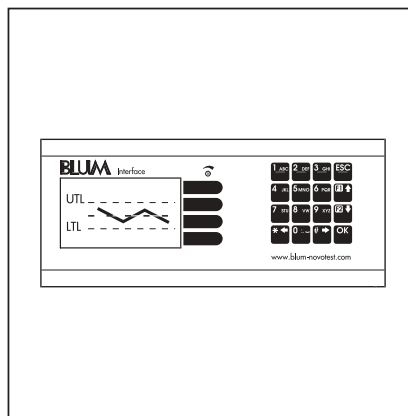

### IF46

Interface IF46 designed for communication between machine controls and bore gauge. Available with integrated SPC and printer interface

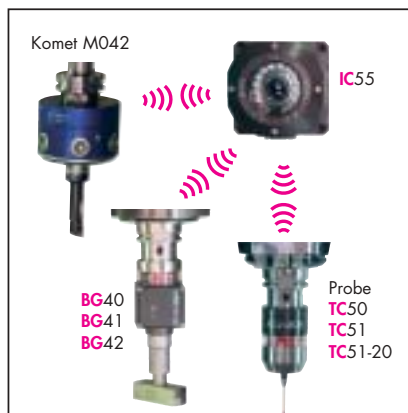

### IC55

- Standard for all products
- IR Controller with microprocessor
- Latest design for data transmission and receiving technology
- Reliable IR Transmission
- Robust design, protection class IP68
- Easy to install and integrate
- Integrated air nozzle

# BG40

## BG40

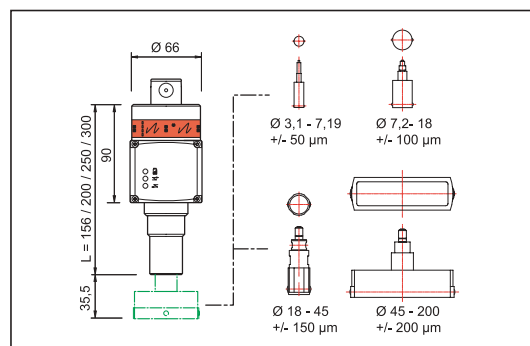

## IC55

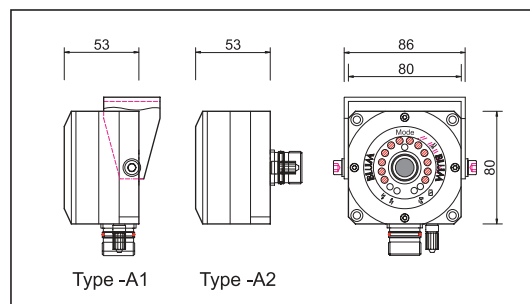

## IF46

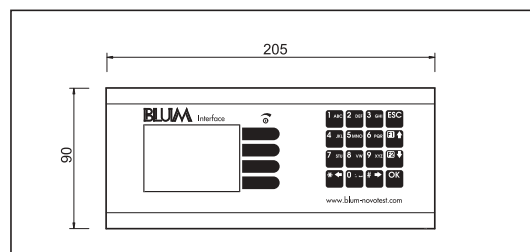

# BLUM

Blum-Novotest GmbH  
Production Metrology

Postfach 1202  
88182 Ravensburg  
Germany  
Tel.: +49 751-6008-0  
Fax: +49 751-6008-156  
www.blum-novotest.com  
E-Mail: vk@blum-novotest.com

Blum LMT Inc.  
4144 Olympic Boulevard  
Erlanger, KY 41018  
USA  
Phone: +001 859-344-6789  
Fax: +001 859-344-6799  
E-Mail: solutions@blumlmt.com

Blum-Novotest Ltd.  
33 Townfields  
Lichfield  
Staffordshire WS13 8AA  
Great Britain  
Tel.: +44 1543-257111  
Fax.: +44 1543-251746  
E-Mail: info@blum-novotest.co.uk

### Technical Data BG40/BG41

Protection class	IP67
Signal transmission	Infrared
Tool holder	Komet ABS 50 / HSK – SK - BT
Transmitter operating range	approx. 3 m ± 60° in Z, ± 360° in X/Y
Battery Life	6LR61 (9V), > 150,000 cycles
Resolution	12 Bit / 0,15 µm
Linearity	1 % of the measuring range
Measuring range	up to 400 µm (depending on diameter)
Weight	1530 g (L=156 mm) incl. measuring head Ø 50 mm

### Technical Data IC55

Protection class	IP68
Power supply voltage	15-30 V DC / 100 mA
Inputs	3 x 10 mA
Outputs	4 x 50 mA Push-pull output
Air nozzle	integrated
Interface	RS232
Transmitter operating range	3 m / ± 25°
Receiver operating range	3 m / ± 50°

Blum Laser Measuring Technology Inc.  
Cincinnati, USA

Blum Laser Measuring Technology Inc.  
Los Angeles, USA

KK Blum Laser Measuring Technology  
Nagoya, Japan

KK Blum Laser Measuring Technology  
Taichung, Taiwan

Blum-Novotest S.A.R.L.  
Bordeaux, France

Blum-Novotest S.R.L.  
Como, Italy

Blum-Novotest Ltd.  
Birmingham, England